

TECHNICAL

ACCESS CONTROL

LIGUARD X[®]

WITH AND WITHOUT POWER SUPPLY

CENTRAL UNIT 2, 4 & 6



MANUAL

Important notes

1) **Software compatibility**

The unit is only compatible with OPTIMA in version 4.8.0 or higher.

2) **Hardware compatibility**

The LIGUARD X2, X4 and X6 have the same pinout for the C-T-R reader relays.

Compared to previous LIGUARDs:

Product	Relay	Comparison	Product	Relay
LIGUARD X2	C-T-R	Inversion de R et T	LIGUARD 2	C-R-T
LIGUARD X4	C-T-R	Identique	LIGUARD 4	C-T-R
LIGUARD X6	C-T-R	Identique	LIGUARD 6	C-T-R

Copyright: © Eden Innovations

No part of this publication may be reproduced, transmitted, transcribed or translated in any form or by any means without the consent of the copyright holder. Unauthorized copying can not only break the laws of copyright but also reduce the ability of Eden Innovations to provide accurate information.

Contents

Important notes	2
1) Software compatibility	2
2) Hardware compatibility	2
Contents	3
Package content	5
1) LIGUARD X® with power supply	5
2) LIGUARD X® without power supply	5
Warranty	5
Information and recommendations	6
1) Cabling recommendations	6
2) Safety instructions	6
3) Standards, guidelines and environmental protection and public health.....	6
4) Safety conditions relating to fire and liability	6
Technical characteristics	8
Installing the case	9
1) General	9
2) LIGUARD® X without power supply	9
3) LIGUARD® X with power supply	11
Controllers overview	14
Terminal functions	18
Connecting the controller to the network	20
1) Ethernet network	21
2) RS485 network.....	23
Dongle	25
1) Licences for SENATORFX.NET/LOG.NET	25
2) Dongle installation	25
Configuring the rotary switch	25
Cabling biometric reader and RS485 extension cards	26
1) Typical wiring	26
2) Wiring rules	27
3) End of line resistors.....	27
Cabling identification technology using Wiegand / Clock&Data	28
2) Wiring rules	28
Cabling a dry contact (push-button, door contact...)	29
1) Typical wiring	29
2) Wiring rules	29
Cabling the burglary case contact	29
Cabling opening systems	30
Maintenance	30
1) Changing the main battery	31
2) Changing the battery	31

DEL signage	32
1) Power supply.....	32
2) Controller.....	32

Package content

When you receive your LIGUARD X® controller, you should find the following items in the package. If any items are missing, please notify your distributor.

1) **LIGUARD X® with power supply**

- 1 case (containing power supply + controller)
- 2, 4 or 6 diodes
- 1 technical manual
- Cables to connect the backup battery
- Cable clamp

2) **LIGUARD X® without power supply**

- 1 case (containing the controller)
- 2, 4 or 6 anti-reverse diodes
- 1 technical manual

Warranty

Eden innovations guarantees that its products will be free from defects in material and workmanship, under normal use, for a minimum period of 5 years from the date of manufacture indicated on the model label or from the date of invoice.

Eden Innovations does not guarantee:

- Products on which the serial number has been damaged, altered or removed.
- Products that are not accompanied by a copy of the original invoice or products for which the data on the original invoice was in any way modified or deleted.
- Damage, deterioration or malfunction resulting from the following situations:
Accident, vandalism, abuse, misuse, neglect, fire, water/liquids, lightning, or other natural damages, unauthorized modification of the product, or inability to follow the instructions supplied with the product.
- Repair or attempted repair by anyone not authorized by Eden Innovations.
- Damage due to product delivery.
- External causes to products such as fluctuations or power outages.
- Normal wear.
- Any other cause which does not relate to a product defect.
- Exposure to an excessively dusty and/or humid environment.
- Products not manufactured by Eden Innovations.

Information and recommendations

1) **Cabling recommendations**

The cables used to connect readers, the network, and other peripherals must be installed in accordance with the instructions for Level 2 (protected environment) of standard NF EN 61000-4-4.

2) **Safety instructions**

To avoid any risk of electrical shock, **ANY WORK** must be performed with **POWER OFF**.

A disconnecting device (switch for example) with a value of 16 A must be installed for this purpose outside the equipment, integrated in the building installation.

Works when the electrical power is on is only authorized when power off is impossible.

Any work should only be carried out by qualified personnel.

The electrical installation must be done according to standard NF C- 15-100.

Non-compliance with these instructions can cause death or serious injury and damage irretrievably the device.

3) **Standards, guidelines and environmental protection and public health**

This product complies with standards CEM EN 55024:2010, EN 55032:2015, EN 61000-3-2:2014, EN 61000-3-3:2013 et EN 62368-1:2014.

EDEN INNOVATIONS manufactures all its products in compliance with environmental directives RoHS and WEEE.

EDEN INNOVATIONS recycles end-life products through its recycling process.



When connecting readers, doors, etc. be careful not to bring dangerous voltage to the controller.

4) **Safety conditions relating to fire and liability**

Never connect badge or biometric reader at a critical point (exit door, barrier, lift gate) if no other exit is available, in order to comply with current regulations relating to fire and life safety. These rules may vary from one place to another and the use of any electronic equipment to control a door must always have prior approval from local authorities. For example, the use of output buttons is not allowed in all towns.

In most cases, anyone must be able to get out of the building using a very simple single action device, even if they are not aware of steps to follow. This is a safety requirement.

Make sure to get all the necessary written authorizations. Accept no oral clearance, they are not valid.

EDEN INNOVATIONS recommends to never use its equipment as first warning systems or monitoring. These equipment must comply with current regulations concerning fire and safety. The installer is responsible for regularly checking the system and informing the end user about test procedures to be performed daily. In case of problems, failure to observe this requirement of regular verification may engage the responsibility of the installer with its customer.

EDEN INNOVATIONS recommends never using its equipment as first warning or surveillance systems. These must always comply with the regulations in force on fire and safety. The installer is responsible for

regularly checking the system and informing the end user of the test procedures to be performed on a daily basis. In the event of a problem, failure to comply with this obligation of regular verification may engage the responsibility of the installer vis-à-vis this customer.

Technical characteristics

Case without power supply:

Weight..... 1, 4 kg
 Dimensions L:235 x l:210 x h:55 mm

Case with power supply:

Weight..... 3,2 Kg
 Dimensions L:370 x l:230 x h:85 mm

Built-in 230 V power supply:

Voltage..... 200-240VAC
 Frequency 50/60Hz
 Output voltage..... 13.8V
 Maximum output current..... 5A
 Temperature..... 0°C +40°C
 Battery connection..... 12V, 7Ah (L:65 x l:151 x h:99 mm)
 Primary fuse (F1)..... 5x20 T3.15AL 250 V
 Output 3 fuse (F2) 5x20 F2.5AL
 Output 2 fuse (F3) 5x20 F2.5AL
 Output 1 fuse (F4) 5x20 F2.5AL
 Battery fuse (FBat) 9A, automatically resettable

Controller:

Voltage..... 12V - 14V
 Maximum consumption..... 200mA
 Temperature..... 0°C +40°C
 Fuse F1 0.75 A automatically resettable

Door control and automation:

Door control relay 30V max & 3A max
 Automation relay 30V max & 3A max
 Open collector output 45V max & 100mA max
 Maximum cable length..... 150m

RS485 Bus Extension, Wiegand/Clock & Data readers:

Maximum consumption..... 2.5A for the readers and the extension bus
 Maximum consumption..... 2.5A per reader
 Maximum consumption..... 2.5A for the extension bus
 Green LED 45V max & 100mA max

Installing the case

1) **General**

The use of boxes indoors is recommended.

Outdoor use must be done in a minimum IP54 enclosure. In the case of a completely waterproof case, lead-acid batteries should not be used.

The product should not be installed at an altitude of more than 2000m.

2) **LIGUARD® X without power supply**

a. Opening the case

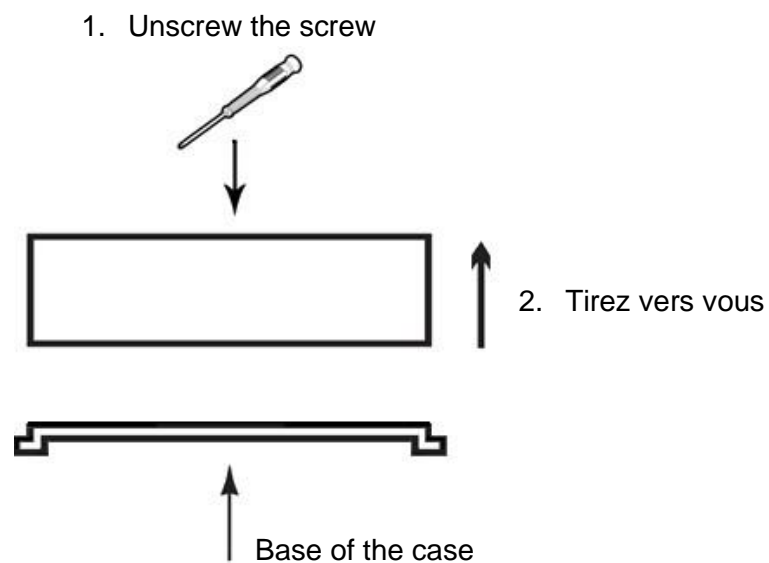

b. Installing the case

Fix the box using the 4 mounting holes of the base.

It is necessary to install and adapt the binding to the type of support.

c. Power supply cabling

Power to the controller must be 12V (maximum 100W).

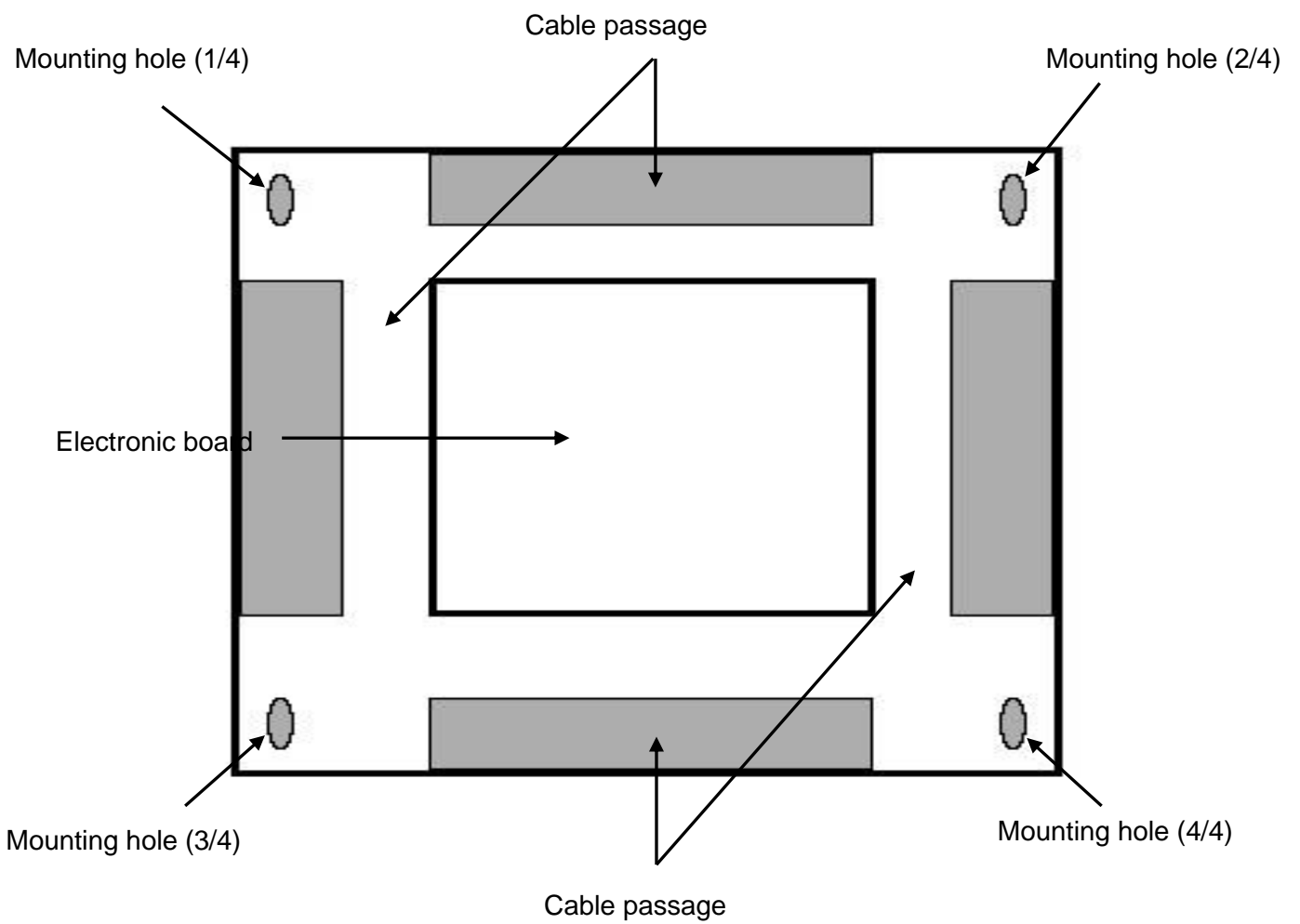

3) **LIGUARD® X with power supply**

a. Opening the case

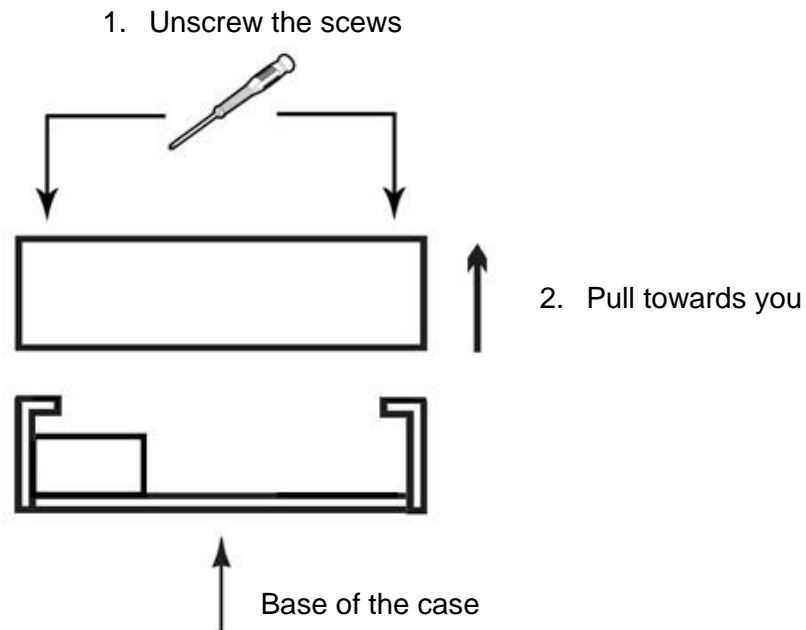

b. Installing the case

Fix the case using the 4 mounting holes of the base.

- It is necessary to install and adapt the binding to the type of support.

c. Power supply cabling

The network power cable must comply with standard IEC60227-1 with a section of 1.5mm².

- Strip between 7 and 7.5 mm.
- Put in the sleeves.
- Use double crimping.
- Hold the 3 wires using a cable tie as close as possible to the connector
- Maintain the power cable at the dedicated fixing.

Connect the mains cable to the mains terminal block as follows:

- The blue wire to the terminal indicated by an N (Neutral)
- The green / yellow wire to the terminal indicated by an E
- The brown wire to the terminal indicated by an L (phase)

Make sure that in the event of poor fixing, the power supply terminal must not be able to touch the metal casing.

The power cable must not be accessible. It must pass directly from the wall to the case, in order to avoid any risk of tearing..

The cabling must comply with local regulations and the installation with CEI **60227** or CEI **60245** stand-ard.

The case must **imperatively** be installed on a wall with the orientation below.

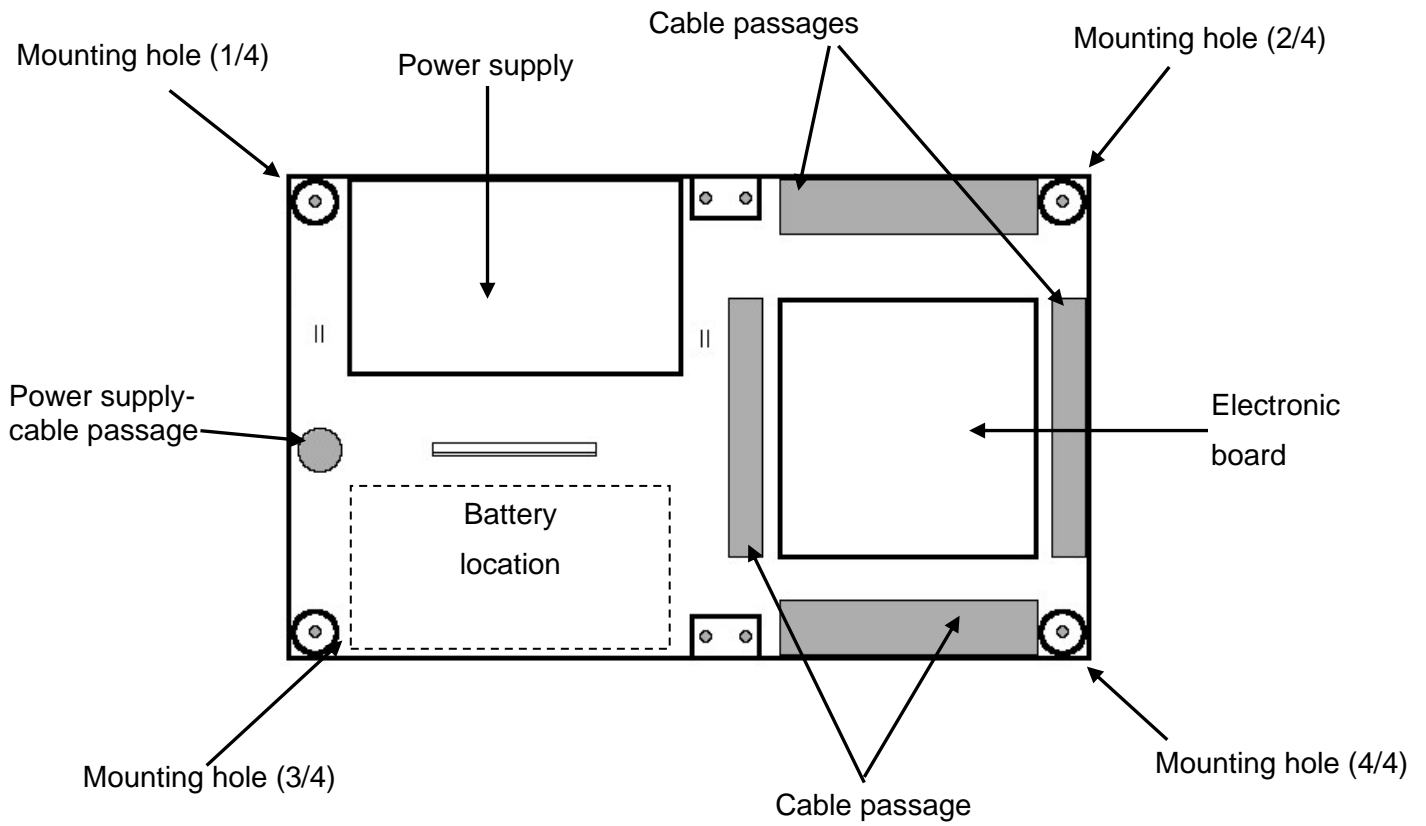

Caution: The cable which connects the power supply to the "functional earth" must not be removed.

d. Starting up the power supply

Open the circuit breaker before connecting anything.
Connect the battery wires to the terminal but do not connect the battery terminals.
Make the electrical connections (mains, use and battery)

1. Close the circuit breaker
2. Check the user output voltage. The AC and DC LEDs on the power supply turn green.
3. Connect the black and red battery wires respectively to the - and + terminals of the battery.
4. Check the correct functioning of the battery. The BATT LED turns green.
5. Close the cover.

The supply power is working when the 3 LEDs are green.

e. Battery

The battery installation procedure is available in the maintenance chapter of this manual.

f. Symbols



Protective ground



Functional ground

Controllers overview

LIGUARD X2

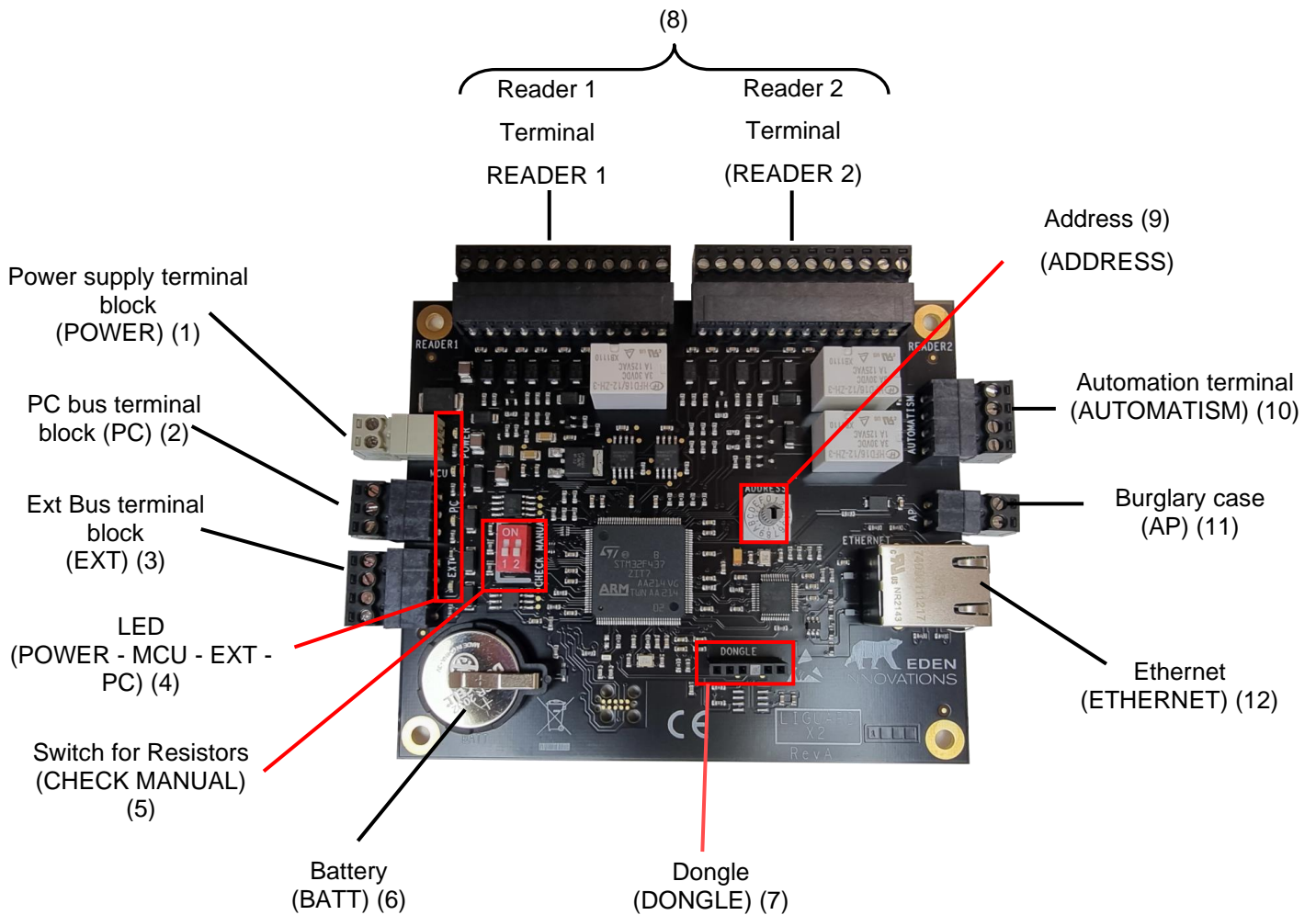

LIGUARD X4

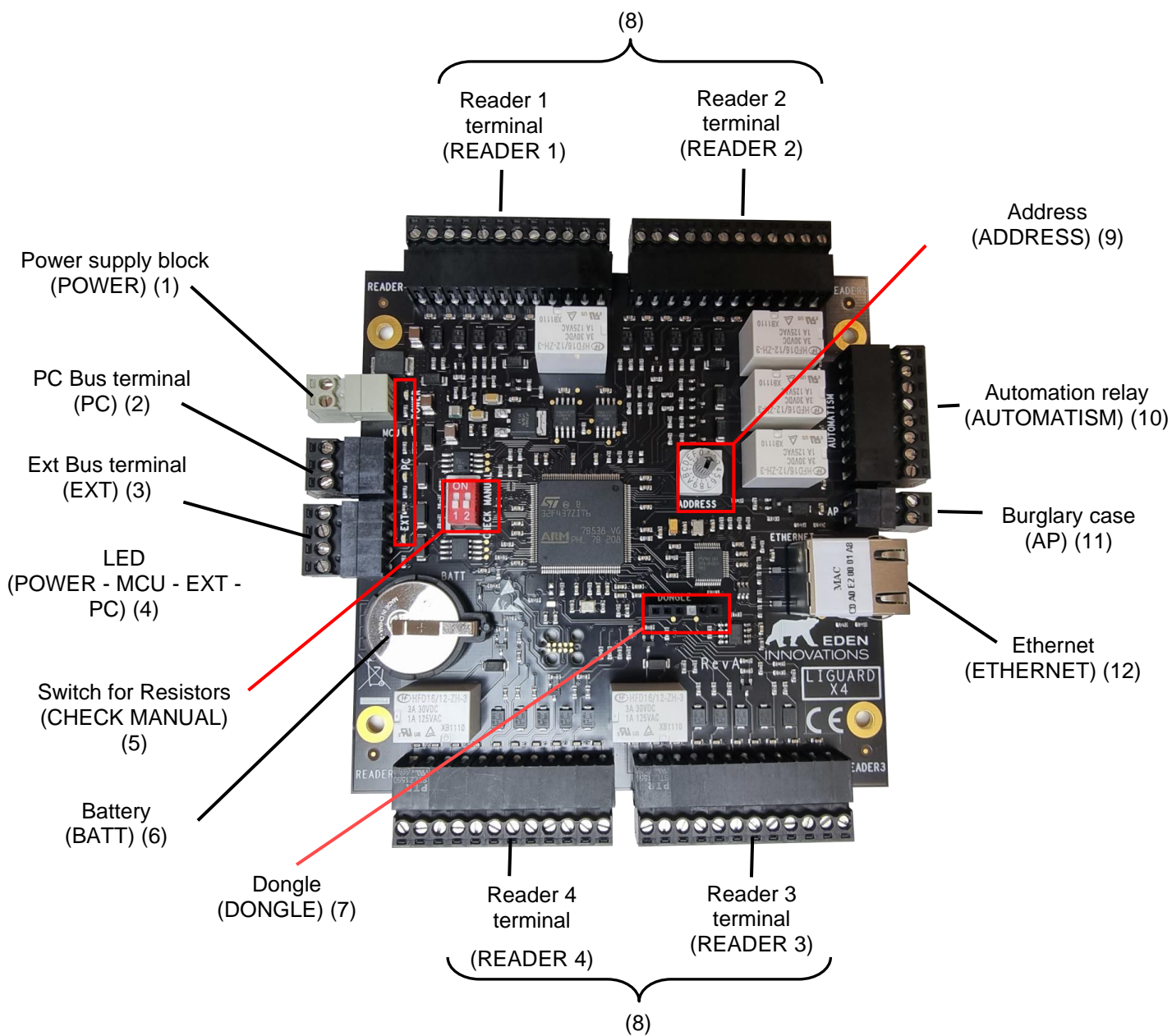

LIGUARD X6

(8)

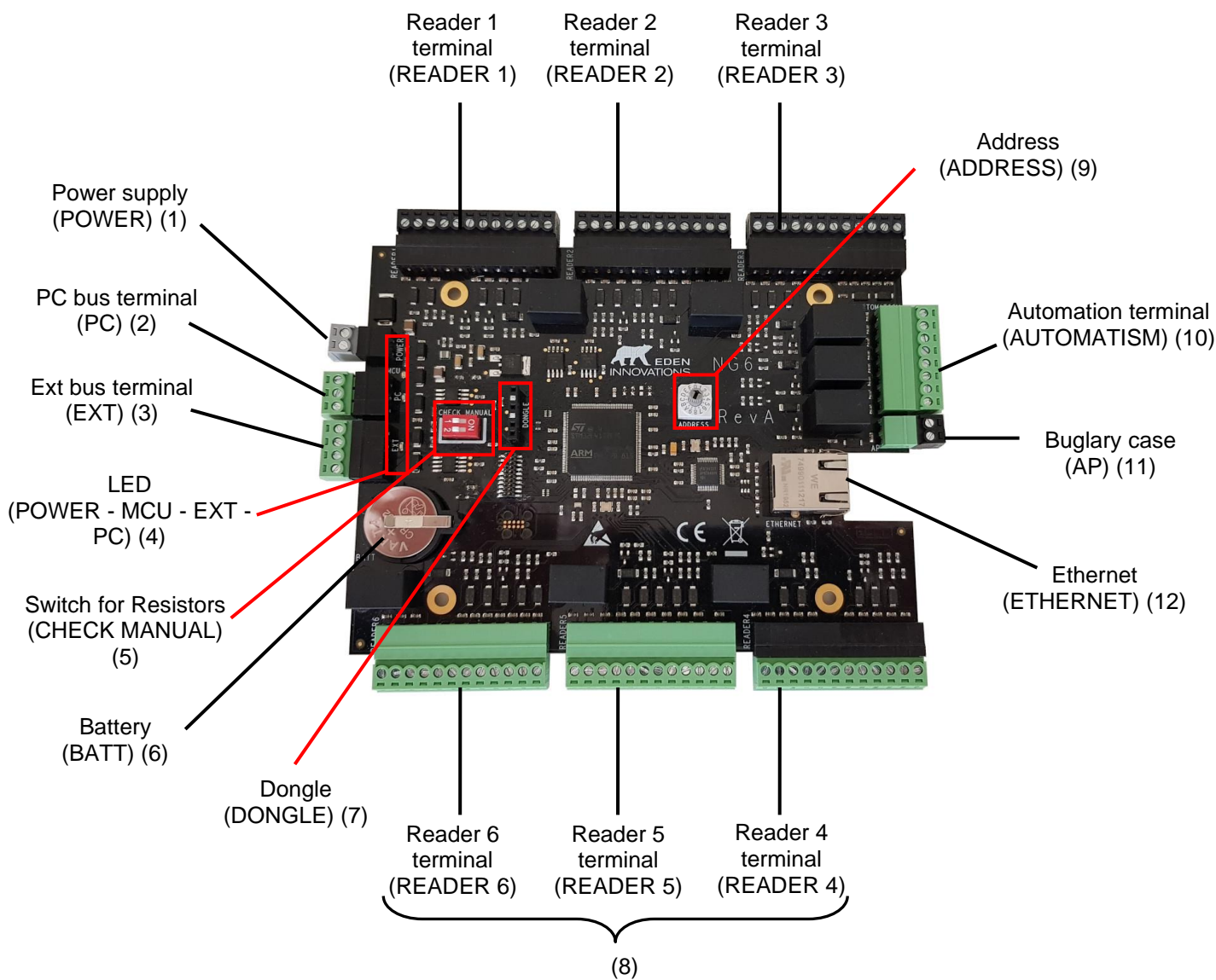

(1) = Controller power supply terminal.

(2) = RS485 connection to the PC.

(3) = RS485 connection to biometric readers and input/output extension cards.

(4) = LED indicators: See details on page page 27.

(5) = Buttons for enabling/disabling 120Ω end-of-line resistors (PC and EXT).

(6) = Backup battery.

(7) = Dongle terminal (software licence). See details on page 19.

(8) = Terminals to connect 6 Wiegand or Clock&Data readers (RFID, magnetic strip, smart card, other biometric readers, etc...).

(9) = Switch to set the bus address. See details on page 18.

(10) = Automations terminal.

(11) = Terminal to connect the burglary case switch.

(12) = Ethernet connector to connect RJ45 cable.

Terminal functions

LIGUARD X2

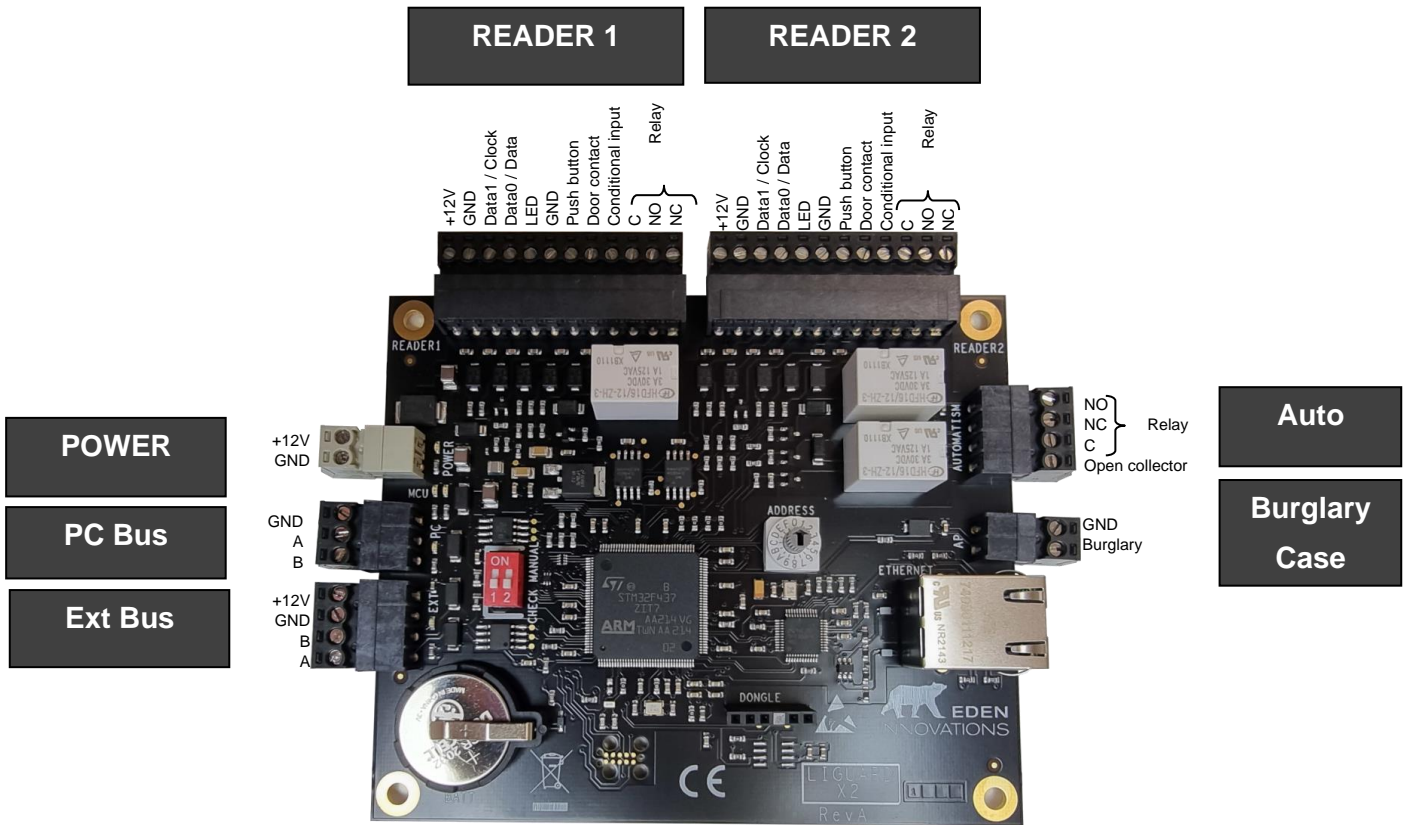

LIGUARD X4

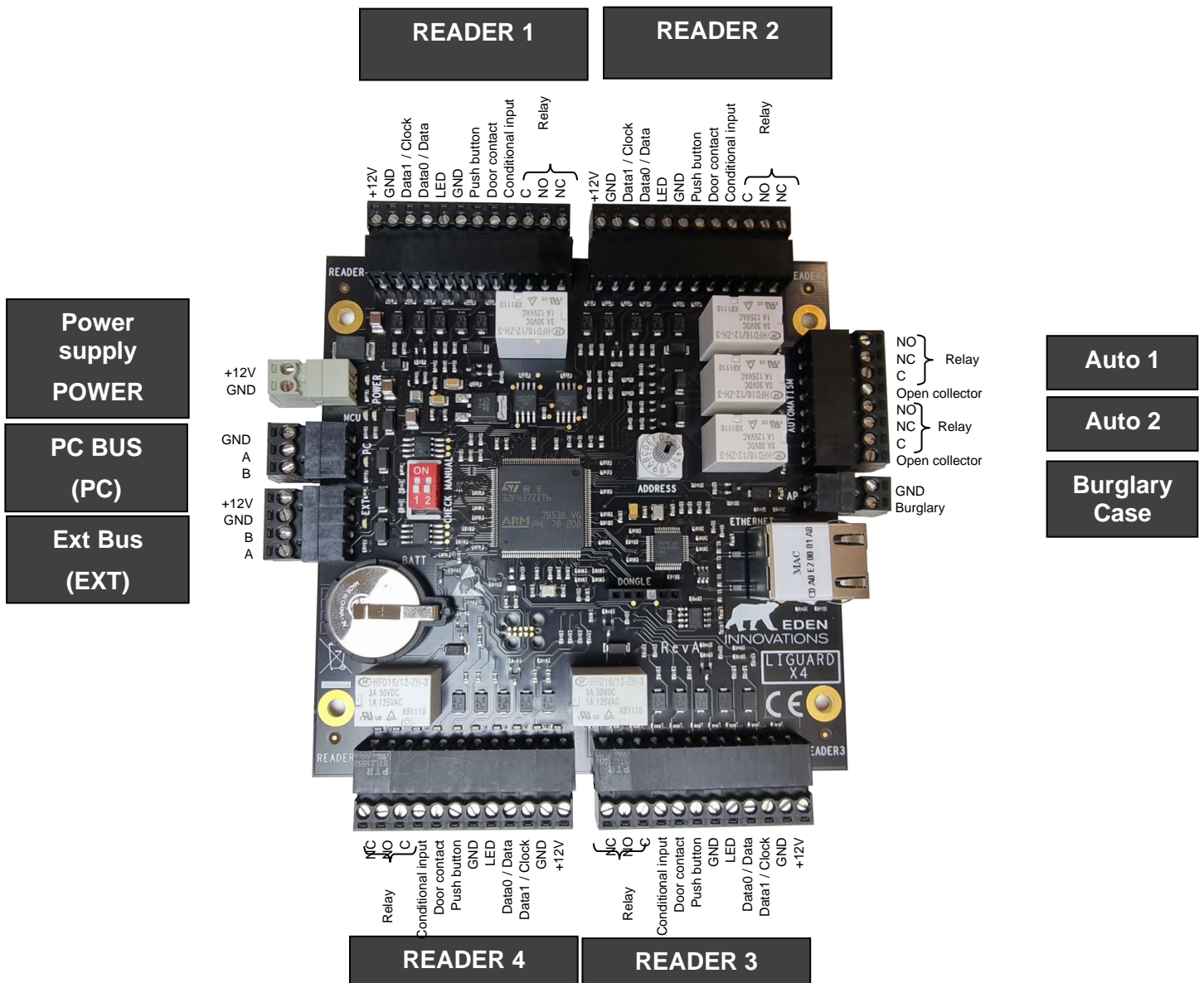

LIGUARD X6

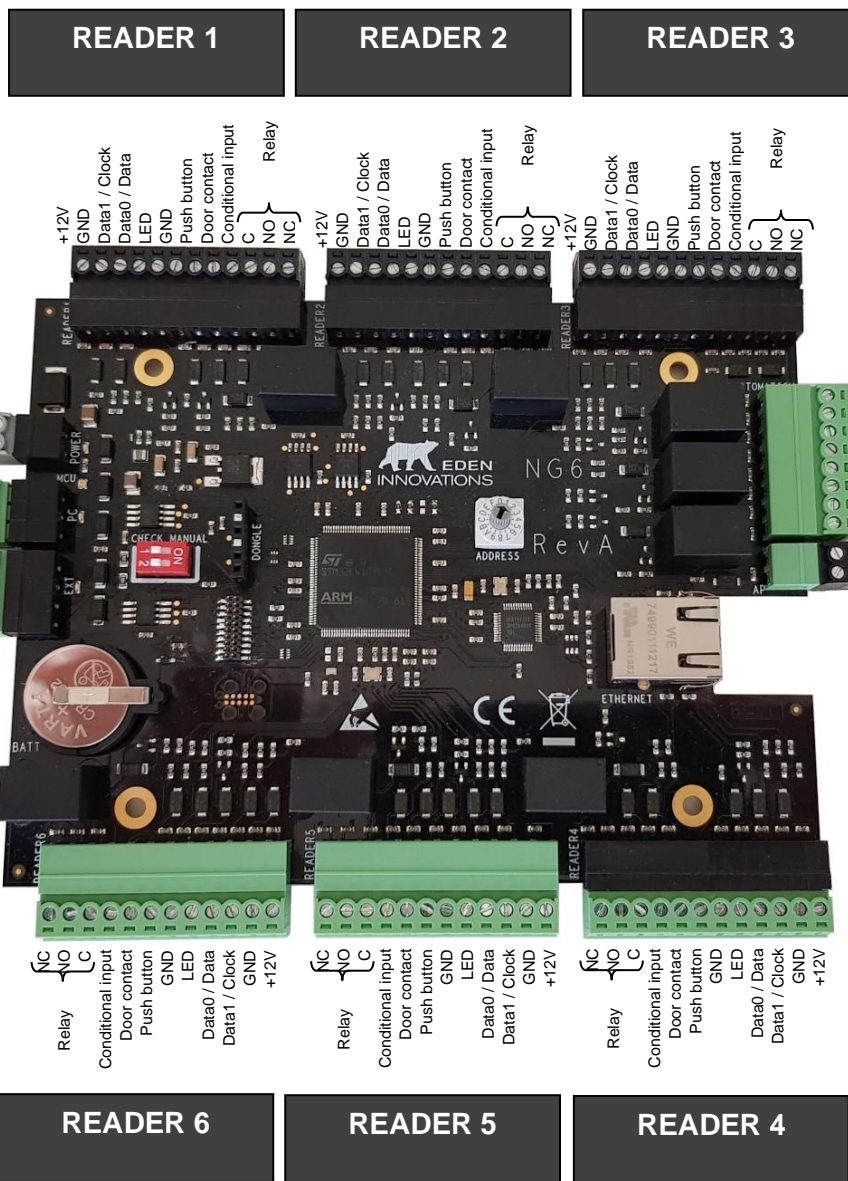

Power supply (POWER)

PC Bus (PC)

Ext Bus (EXT)

Auto 1

Auto 2

Burglary (AP)

NO } Relay
 NC }
 C }
 Open collector
 NO } Relay
 NC }
 C }
 Open collector
 GND
 Burglary

Connecting the controller to the network

1) *Ethernet network*

The BUS or IP communication mode is automatically detected by the controller.

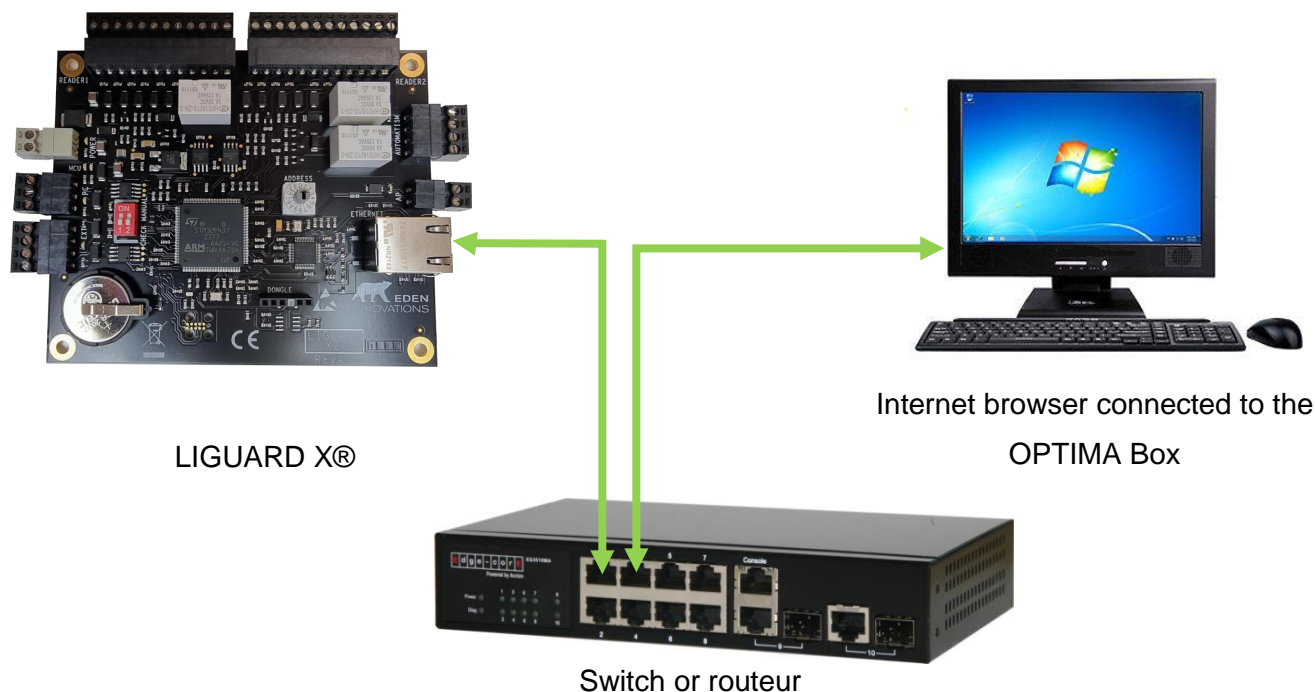

Please use RJ45 Cat6 F-STP shielded or higher quality cable.

The maximum length of the cable between the controller and the Switch must not exceed 100m

The use of the PoE (Power over Ethernet) function on the Ethernet bus is not permitted.

a. MAC address

The MAC address is located on the RJ45 connector on the electronic board.

MAC
C0 :A0 :E2 :00 :01 :00

b. IP Address

The default IP addresses of the controllers are:

Unit	Default IP address
LIGUARD X2	192.168.3.153
LIGUARD X4	192.168.3.154
LIGUARD X6	192.168.3.155

To restore the default IP parameters, position the rotary switch on "E" then restart the controller.

Wait a few seconds for the BUS and PC LEDs to stay on continuously. A click of the relays also signals the end of the reset.

2) **RS485 network**

The BUS or IP communication mode is automatically detected by the controller.

a. Cabling

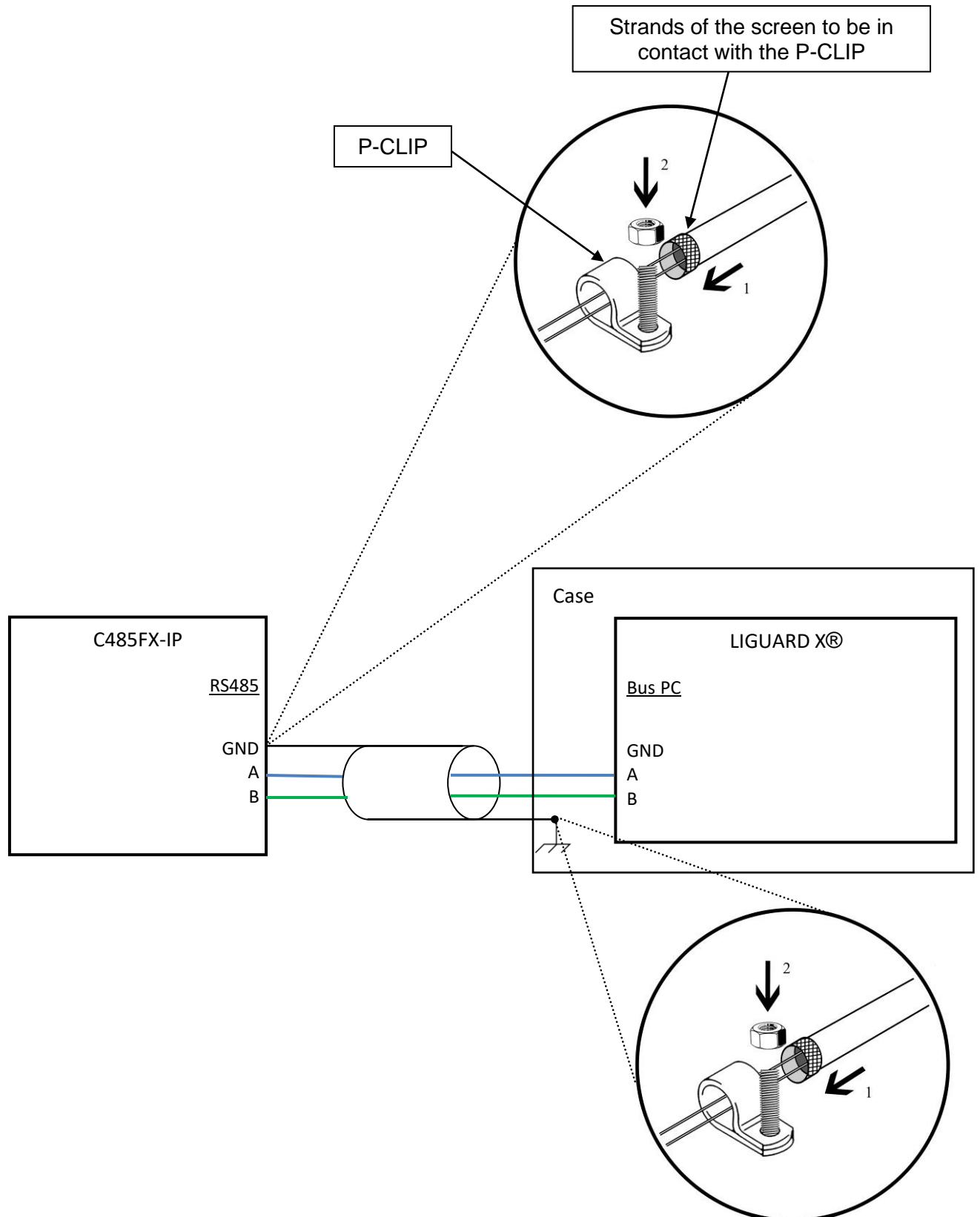

b. Wiring rules :

- The C485FX-IP interface is connected to the 3-pin PC bus terminal block of the LIGUARD X® controller.®.
- Wiring must be in series. So it should not be star or tree for electromagnetic interference reasons.
- The cable used for communication must be twisted, shielded and equipped with 2 pairs. The cable cross section must be 0.6mm (22AWG) with characteristic impedance of 120Ω. We recommend Belden 3107A or AlphaWire 6455 BK005 for installations subject to strong interference. If there is no strong interference, Belden 8723 may be used.
- The bus must be equipped with resistors with a value of 120Ω between points A and B, at each end. The LIGUARD X® controller is pre-equipped with a 120Ω resistor that can be activated by setting switch 1 to ON. The maximum number of connected products is 10 items.
- The maximum number of connected products is 10 items.
- The link must not exceed 1200 meters.
- Shielding is mandatory.
- This link is a data bus, it must be far away as possible from other cables.
- **Make sure to use the same pair for A and B.**

c. Addressing switch

Caution: The addressing and the communication mode must be carried out **BEFORE** switching on the controller.

The rotary switch allows the addressing of the controller on the network. The controller identifier corresponds to the number configured by the rotary switch: from 1 to 10 (the 0 corresponds to the bus address 10). More information in the chapter “Configuring the rotary switch”.

d. End of line resistors

The controller is equipped with integrated end-of-line resistors that can be activated/deactivated manually.

Button	Position	Terminal	End of line resistors (120Ω)
1	ON	PC	Enabled
	OFF		Disabled
2	ON	EXT	Enabled
	OFF		Disabled

Dongle

1) *Licences for SENATORFX.NET/LOG.NET*

SENATORFX.NET and LOG.NET software require a license from 6 readers.

OPTIMA Box does not require any license.

DONGLE	Designation
DONGLEFXCD16	License to connect up to 16 readers on the same installation.
DONGLEFXCD512	License to connect up to 512 readers on the same installation.

2) *Dongle installation*

In order for the SenatorFX.NET® software to work, you must install a Dongle on one of the controllers of your installation.

Dongle connector

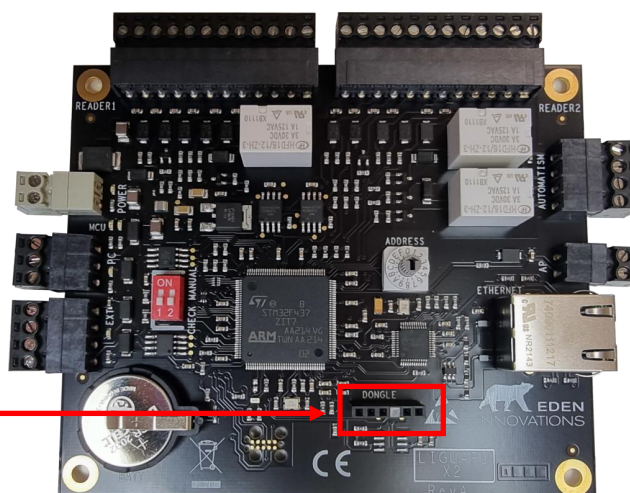

Configuring the rotary switch

Value	Funtion
1 à 9	Address 1 to 9
0	Address 10
A, B et C	Not to use
D	Hardware reset (memory and IP)
E	IP Reset
F	Forced update

Cabling biometric reader and RS485 extension cards

1) Typical wiring

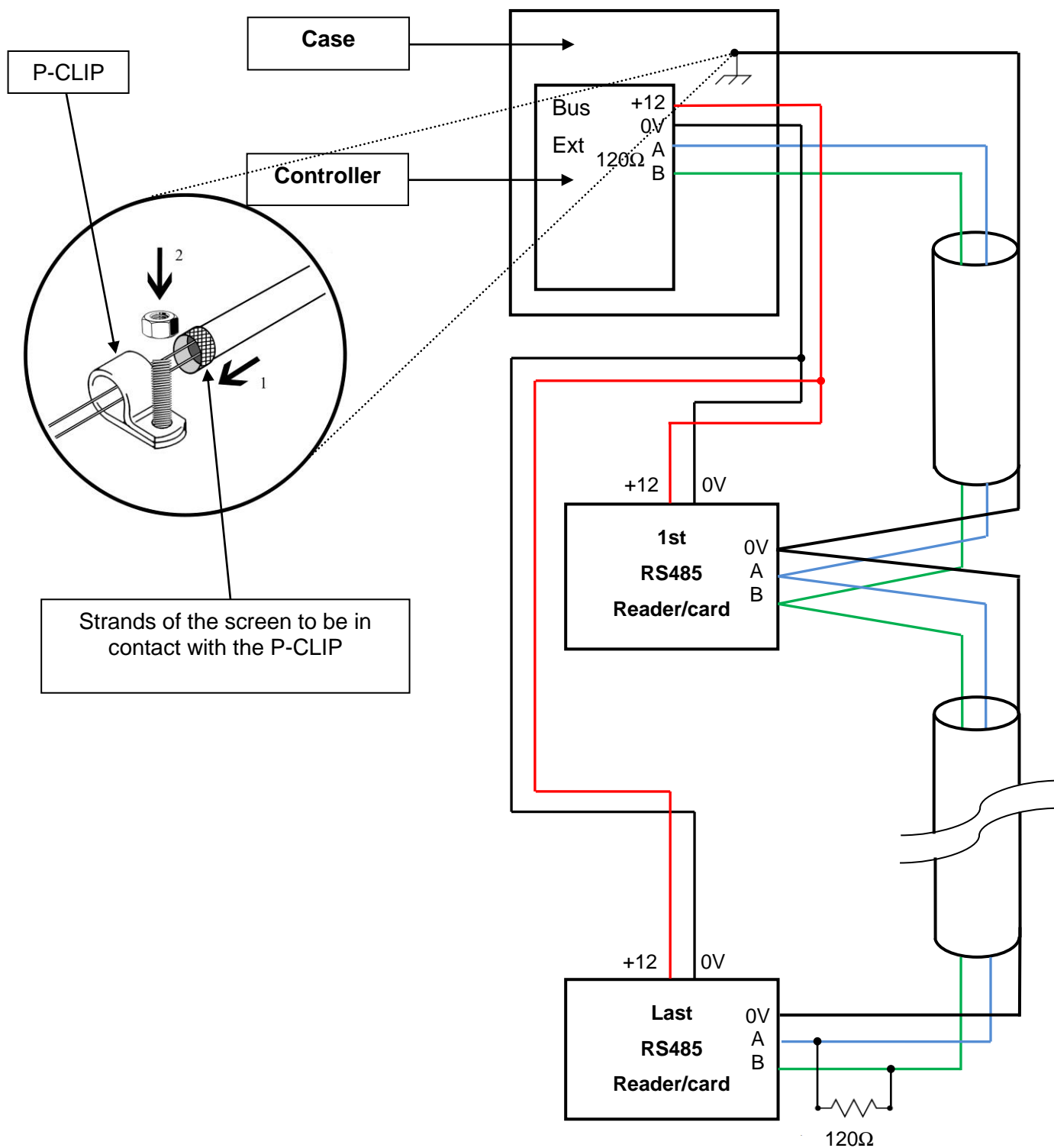

2) **Wiring rules**

- EDEN INNOVATIONS biometric readers and extension cards are to be connected to the EXT terminal of the LIGUARD® X controller. This terminal block has a power supply to power the biometric readers and extension cards.
- The wiring must be in series. The wiring must not be star or tree to avoid electromagnetic interference.
- The cable used for communication must be twisted, shielded and equipped with 2 pairs. The cable cross section must be 0.6mm (22AWG) with characteristic impedance of 120Ω. We recommend Belden 3107A or AlphaWire 6455 BK005 for installations subject to strong interference. If there is no strong interference, Belden 8723 may be used.
- The bus must be fitted with resistors with a value of 120Ω between A and B, at each end.
- The link must not exceed 1200 meters.
- Shielding is mandatory.
- This link is a data bus, it must be far away as possible from other cables.
- **Make sure to use the same pair for A and B.**

3) **End of line resistors**

The controller is equipped with integrated end-of-line resistors that can be activated/deactivated manually.

Button	Position	Terminal	End of line resistors (120Ω)
1	ON	PC	Enabled
	OFF		Disabled
2	ON	EXT	Enabled
	OFF		Disabled

Cabling identification technology using Wiegand / Clock&Data

1) Typical wiring

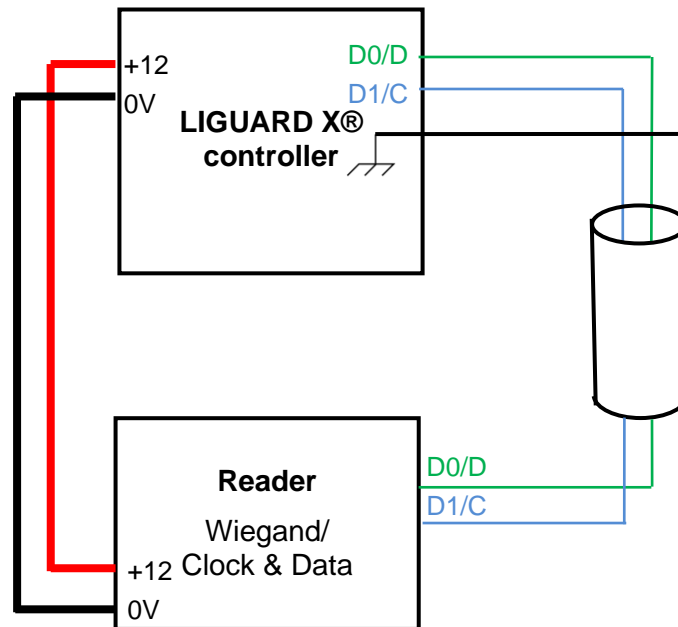

2) Wiring rules

- The cable used for communication must be shielded and equipped with 3 pairs. The cable cross section must be 0.6mm (22AWG).
- Only one reader can be connected per bus.
- The link must not exceed 150 meters.
- Shielding is recommended.
- This link is a data bus, it must be far away as possible from other cables.
- You can connect readers using different technology (example: Reader 1 Wiegand, Reader 2 Clock&Data).
- If you use a third power for the reader, you **must** have a common earth for the controller and the reader.

Cabling a dry contact (push-button, door contact...)

1) *Typical wiring*

Cabling a push-button :

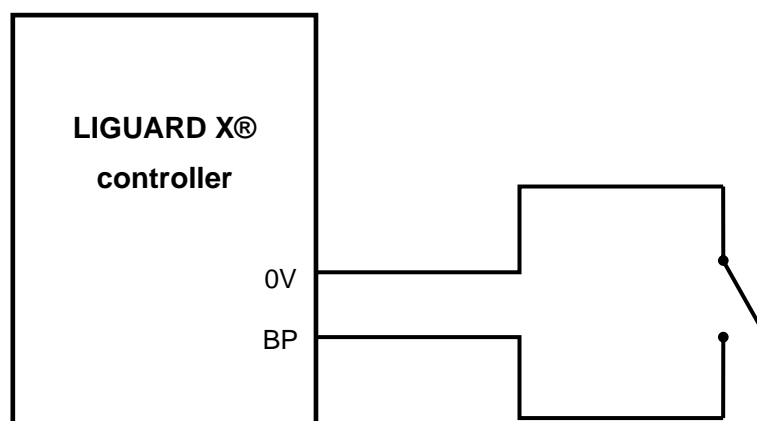

2) *Wiring rules*

All inputs on a reader terminal of a LIGUARD 2® controller connect to the GND.

Cabling the burglary case contact

To do this, use an NO or NC type switch or microswitch (software configurable).

This is the “anti-theft kit” in our catalogue.

A slot is provided on the base of the LIGUARD X® box with power supply.

Cabling opening systems

Caution : Whatever the connection method and whatever the opening system, it is essential to set up the non-return diodes supplied with the controller.

a) Power failure door activator and electromagnetic door lock triggered by a power failure

Typical wiring:

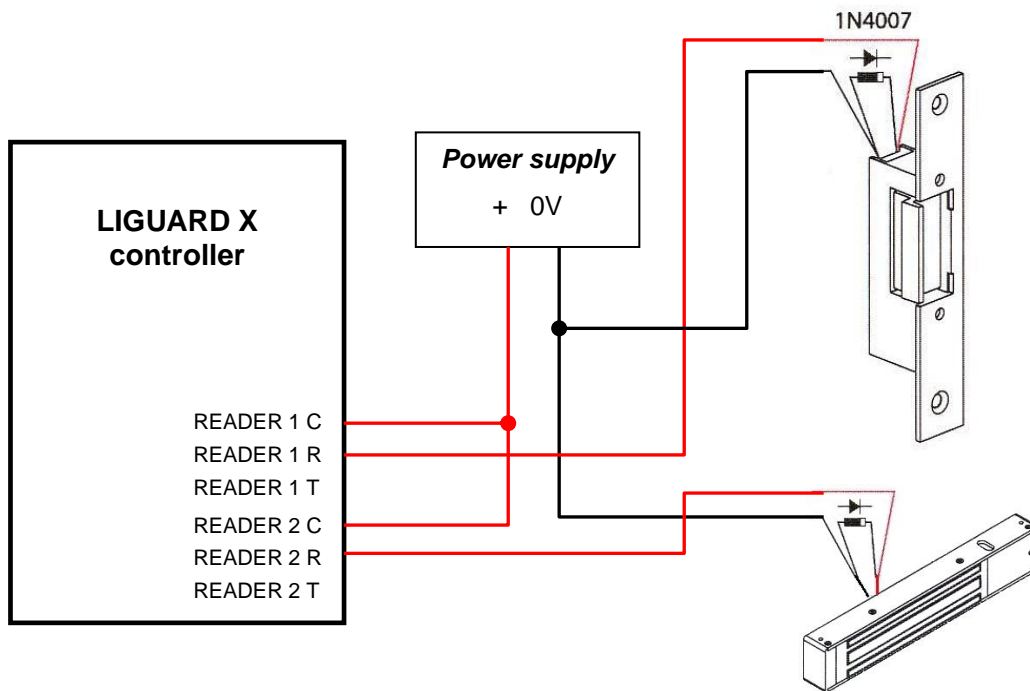

b) Door activator triggered by a voltage pulse

Typical wiring:

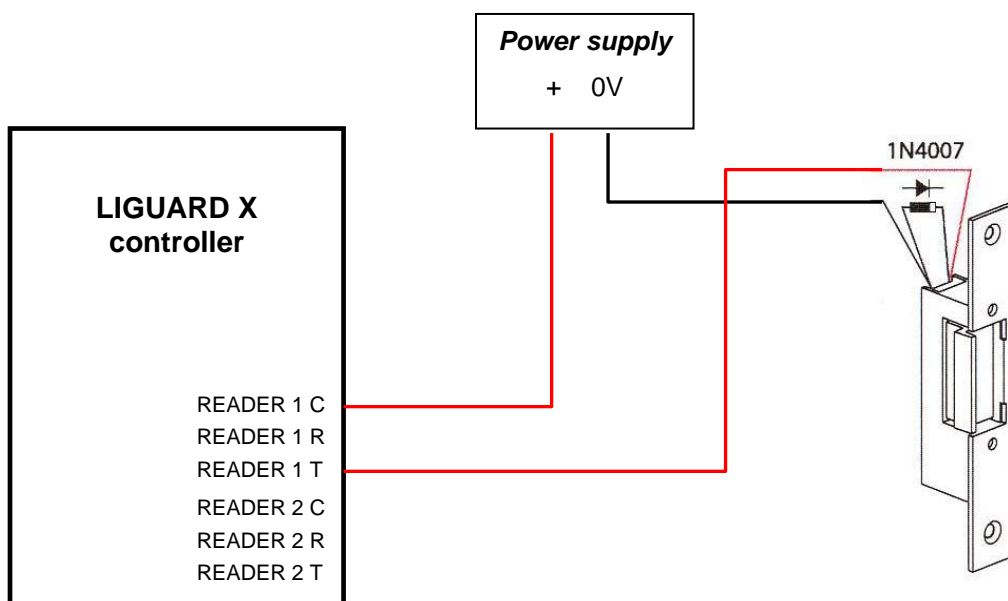

Maintenance

This section gives you the important elements to consider when maintaining the LIGUARD® X controller.

Caution :



There is a risk of explosion if the cell or the battery are replaced by an incorrect type or battery. Dispose of used batteries and cells in accordance with the instructions in force in the country of use.

1) Changing the main battery

The use of a lead acid battery is strongly recommended.

The characteristics of the battery to be installed are:

Specifications	Value
Charger voltage (V)	12
Charger rating (A)	6
Maximum battery charge current (A)	4,5
Maximum capacity (Ah) - C20 - 1.75V	86
Minimum capacity (Ah) - C20 - 1.75V	7

Connection :

1. Unscrew the 2 battery support fixing screws.
2. Orient the battery so that the connection terminals are towards the inside of the box, towards the power supply.
3. Connect the black and red battery wires respectively to the - and + terminals of the battery.
4. Reattach the holder and check that your battery does not move.

2) Changing the battery

In order not to lose the list of events and the IP parameters stored in the controller, the battery must be replaced when the LIGUARD X® is powered up.

The battery must be replaced with a CR2032 type battery.

DEL signage

1) *Power supply*

DEL	Status	Meaning	Solution
AC	ON	The controller is correctly powered	-
	OFF	The controller is not powered	Check the power supply
DC	ON	DC output active	-
	OFF	DC output inactive	Check the power supply Use a battery
BATT	ON	Battery is connected	-
	OFF	Battery empty or missing	Recharge the battery or replace with a new one

2) *Controller*

DEL	Status	Meaning	Solution
POWER	ON	The controller is correctly powered	-
	OFF	The controller is not powered	Check the power supply
MCU	OFF	Software issue	Restart controller
	ON	Software issue	Redémarrer la centrale
	Flashing blue	The microcontroller works	-
	Flashing red	Update in progress	Wait for the update to complete
EXT	Fast flashing	Communication is established	-
	Intermittent flashing	Communication with some RS485 products is problematic	Check cabling/power supply of RS485 products
	OFF	No communication	Ok, if no RS485 product If not, Check the cabling/power supply of the RS485 products
PC	Flashing	Communication is established	-
	OFF	No communication with the software	Check network settings / installation / software

Technical support :

support@eden-innovations.com

EDEN INNOVATIONS



Zone Commerciale et Artisanale

670, route de Berre

13510 EGUILLES

France

www.eden-innovations.com